

(b) End grab irons. There are two type of end grabs. The "U-shaped" Grab Irons (s) are attached to the bottom of the car body. The End Grab Irons (u) that are attached using the locator holes in the end ribs have asymmetrical brackets. The short portion of the bracket for these grabs goes towards the top of the car.

Step 6: Side Ladders (q), Side Grab Irons (t) and Stirrups (z)

(a) Side ladders. Remove side ladders (with stirrups) from the parts sprue and glue one to each side of the car using the complimentary four locators and four locator holes. The projections at the top of each ladder are "stand-offs" and have no locator holes provided for them. In each case the side ladder goes to the right end of the side.

(b) Side grab irons. The side grab irons have symmetrical brackets. Two grab irons are placed on the left end of each side of the car. They are provided with "diagonal" locators and locator holes so that there can be no mistake about their placement.

(c) Stirrups. Glue in place on the car underbody below the side grab irons. No locators are provided. The outside edge of the stirrup should line up with the outside edge of the side grab irons.

Step 7: Doors (d)

Remove the doors from their sprue and glue in place on car body. Doors do not operate but may be placed in closed, partly open, or fully open position as desired.

Step 8: Continuation of Step (1), Roof and Roofwalk

(a) Test fit roof to car body. If weight is to be added do it now! When ready glue roof to car body. Then glue Roofwalk Grabs (ff) to roofwalk using locators.

(b) Roofwalk mounting brackets (v). Glue in place as shown in drawing. No locators are provided.

NOTE: Your car is now ready to put into service on your rail empire. We hope that you have enjoyed building this model. We welcome your comments on this kit and also suggestions for future projects. If you find that a part is missing or defective, or if you should break or lose one, please contact your dealer or write to us for a replacement.

THANK YOU FOR PURCHASING AN INTERMOUNTAIN KIT!!

INTERMOUNTAIN RAILWAY COMPANY

P. O. Box 839, Longmont, Colorado 80502

Phone: (303) 772-1901 Fax (303) 772-8534

PS-1 40' Boxcar

PARTS LIST

- | | |
|--------------------------------|-----------------------------------|
| 1. Body (a) | 7. Body Detail Sprue: |
| 2. Roof (b) | 2 Long Side Ladder w/ Stirrup (q) |
| 3. Roofwalk (c) | 2 Long End Ladder (r) |
| 4. Doors (d) | 4 U-Shaped Grab Iron (s) |
| 5. Underframe Sprue: | 6 Side Grab Iron w/ Mount (t) |
| 1 Underframe (e) | 3 End Grab Iron w/ Mount (u) |
| 2 Coupler Box (f) | 2 Roof Walk Mounting Bracket (v) |
| 2 Coupler Box Cover (g) | 1 Brake Wheel Housing (w) |
| 6. Underframe Detail Sprue: | 2 Brake Step Bracket (x) |
| 2 Glad Hand (h) | 1 Brake Step (y) |
| 1 Air Tank & Air Lines (i) | 2 Stirrup (z) |
| 1 Triple Valve & Air Lines (j) | 4 Large Tack Board (aa) |
| 3 Large Frame Brace (k) | 2 Small Tack Board (bb) |
| 6 Small Frame Brace (l) | 1 Brake Wheel (cc) |
| 1 Bell Crank, Chain & Rod (m) | 1 Brake Rod & Chain (dd) |
| 1 Long Train Line (n) | 1 Air Line & Valve (ee) |
| 1 Brake Cylinder & Rods (o) | 2 Roofwalk Grab Iron (ff) |
| 1 Short Air Line (p) | 6 Short Ladder (A) |
| | 2 Lower Step (B) |

RECOMMENDED TOOLS

Xacto Knife Fine Clippers Small File or Emery Board Pin Vice
Small Drill Set Liquid Styrene Cement Small Phillips Screwdriver

Please read the instructions, study the drawings and parts before assembling them. Some of the detail parts are very fine and delicate. The best way to remove them from the sprue is with fine clippers or an Xacto knife. DO NOT ATTEMPT TO BEND, TWIST, OR BREAK OFF THE PARTS!!

Before gluing any of the parts, test fit and check for flash. When attaching small parts, use tweezers or a blade to help hold them. Small amounts of glue are needed to affix styrene plastic.

PS-1 40' BOXCAR INSTRUCTIONS

Step 1: Roof (b) and Roofwalk (c)

There are two methods of attaching the roofwalk to the roof. Method (b) below is the easiest of the two methods, but we believe that method (a) produces the best result. The choice is yours.

(a) Remove the four locator posts from the bottom side of the roofwalk, and smooth the area by lightly scraping with a small file, knife, or by sanding it. Pat a small amount of glue on each of the mounting brackets on the roof, on the underside of the roofwalk, and on the locator pins on the ends of the roofwalk extensions. Set assembly aside to dry and for later use.

(b) Using a 3/32nds inch bit, drill four holes through the roof at the "dimples" on the underside of the roof. Place the locators on the roofwalk through the resulting holes, and glue the walk in place. Set assembly aside to dry and for later use.

Step 2: Underframe (e) and Underframe Details

(a) Remove the underframe (e) from the underframe sprue. The short projections between the runner and the underframe are "gates" and should be trimmed from the underframe members. Carefully remove the long train line (n) from the underframe detail sprue. The ends of the train line should be separated at the point at which the train line meets the runner. The "gates" along the train line should be removed. The train line must be "threaded" through the two adjacent holes in the center frame member. If there is any flash in either of the two holes it must be removed. Carefully thread the train line through the two holes so that the angled portion of the train line penetrates the main frame member, and the ends of the train line rest on their respective cross members at the ends of the underframe. The train line passes outside, or away from the car body, with respect to the thin cross members, and fits into the grooves toward the car body on the thicker cross members. (HINT: If the long train line breaks during assembly, the resulting pieces may be easily glued into place as described.)

(b) Glue the air tank and air lines (i) in place on the underframe using the two locator holes on the thick cross member, the groove on the thin cross member, and the two grooves for the air lines on the center frame member.

(c) Large Frame Braces (k). Attach the two large frame braces in the "gap" between the halves of the thick center cross members.

(d) Small Frame Braces (l). Attach the five small frame braces placing the locator pins at each end of the brace in the locator holes on each side of the center frame member in line with the thin cross members.

(e) Remove all of the center sprue from the bottom of the car. (This is the point at which the plastic enters the mold to form the car body.) Glue the underframe in place on the car body. There is a locator pin on the underframe and a locator hole on the car body so that the part will fit only one way.

(f) Brake cylinder and rods (o). Attach brake cylinder and rods assembly to the bottom of the underframe using the several locators provided.

(g) Triple Valve and Air Lines (j). Attach the triple valve using the two locators on the bottom of the valve and the two locator holes in the bottom of the car body. The two air lines projecting from the triple valve will appear to be passing through the center frame member to the air tank.

(h) Short Air Line (p). The short air line passes from the "T" in the train line to the triple valve.

(i) Bell Crank, Chain and Rod (m). Attach this assembly using the long locator and the locator hole on the car underbody below the brake step and the locator on the bolster. When in place the clevis on the brake rod is attached to the bell crank.

(j) Glad hands (h). Attach the glad hands using the locator on the bottom of the car body beside the coupler box mounting pad.

Step 3: Trucks and Couplers

(a) Mount couplers in coupler box (f) and glue cover (g) in place. (Kadee #5 couplers are recommended.) When dry, attach to car body using locator provided.

(b) Assemble truck sideframes and wheelsets and fasten to car body with screws provided.

Step 4: "B" or Brake End Detail (The details in this step are found only on the brake end of the car.)

(a) Brake Wheel Housing (w) and Brake Wheel (cc). Set the car on end, with the end having the most locator holes facing up. Remove the Brake Rod and Chain (dd), the brake wheel housing, and the brake wheel from the parts sprue and prepare them for assembly. Glue the locator pin at the end of the chain into the locator hole in the back of the brake wheel housing that does not extend through the part. Attach the resulting assembly to the car body placing the four locator pins on the back of the brake wheel housing in the matching locator holes at the top of the brake end of the car body. Glue the brake wheel in place in the locator hole in the center of the brake wheel housing.

(b) Brake Step (y) and Brake Step Brackets (x). Remove brake step and brackets from sprue. Attach brackets to the car body placing locator pins in the four locator holes adjacent to the chain. Flat surfaces of the mounting brackets should be facing upward. Glue brake step in place on the top of the mounting brackets. Notch in step fits around chain. Recessed areas on underside of step are provided to fit over brackets. The brake step, when in place, should be about 1/16 inch from car body.

(c) Air Line and Valve (ee). Remove air line and valve from parts sprue. Attach to end of car body using three locators on back of part and three locator holes in a vertical line just left of the brake wheel.

Step 5: End Ladders (r) and Grab Irons

(a) End ladders. End ladders are easily distinguishable from side ladders as they have no stirrups at the lower end of the ladder. Remove both end ladders from the detail parts sprue. Attach one ladder to each end of the car body using the four locators. The two projections just below the top of the ladder are "stand-offs" and have no corresponding locator holes. They can be held in place using a small amount of glue if desired.

PS-1 40' BOXCAR

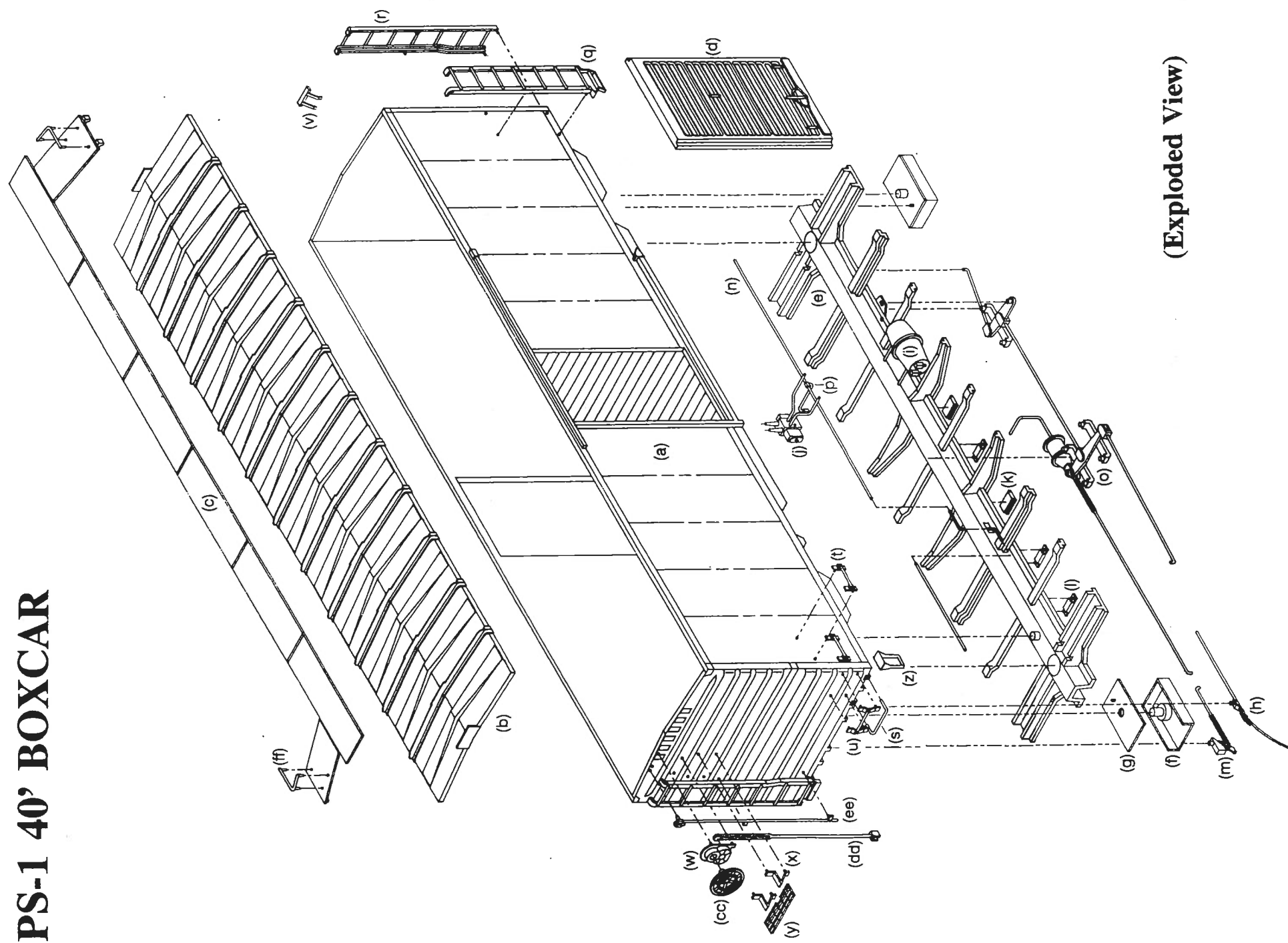

(Exploded View)

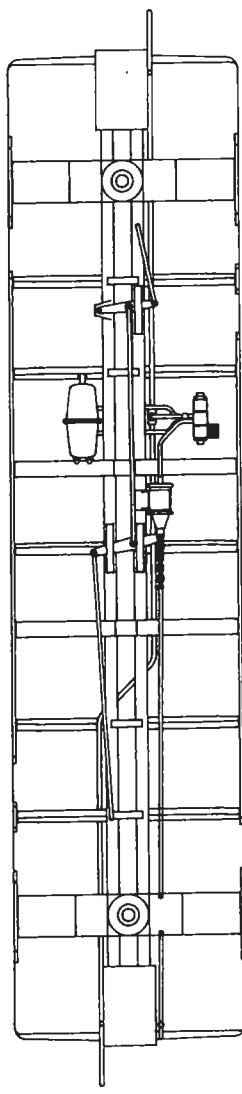

(Underframe Detail)

Modernization Package for PS-1 40' Boxcar

Many of the more recent PS-1 boxcars had a much different ladder arrangement than the "originals". We have provided you with the means of building these models by including a series of short ladders and lower steps in your kit. Each prototype was different, therefore we have shown a generic arrangement in the drawings below. We leave it to you, the modeler, to determine the correct pattern in the drawings below. The parts for this modification are labeled with capital letters (A and B).

